

E-48 Series Universal Advanced Controller Quick Start Guide

Manufacturer / Technical Support :
Elimko Elektronik İmalat ve Kontrol Ltd. Şti.
ASO 2. Organize Sanayi Bölgesi Alçı OSB Mahallesi
2001. Cad. No:14 Temelli 06909 Ankara / TÜRKİYE
Tel: +90 312 212 64 50 (Pbx) • Fax: +90 312 212 41 43
E-mail: elimko@elimko.com.tr • www.elimko.com.tr



1. DESCRIPTION

E-48 Series general purpose process controllers are industrial devices in 1/16 DIN (48x48 mm IEC/TR 60668) dimensions designed by using new generation microcontrollers with on/off, PID and other control forms. Inputs and outputs can be easily programmed by the user.

In E-48 Series controllers, set value and measured value can be displayed from -1999 to 9999 on two 4-digit displays and general purpose inputs (T/C, R/T, mV, mA) can be programmed.

2. DIMENSIONS and PANEL CUT-OUT

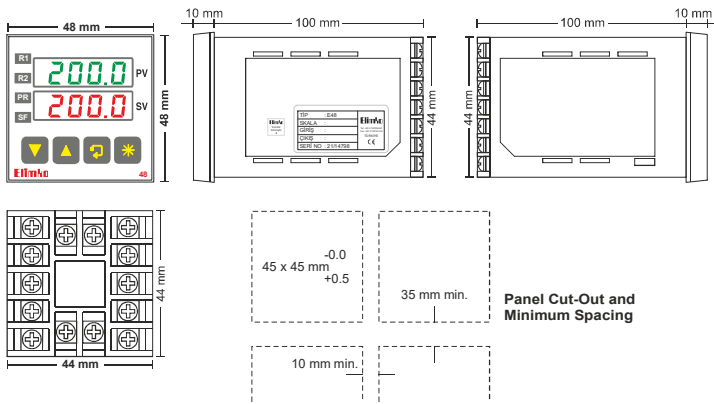

3. CONNECTION DIAGRAM

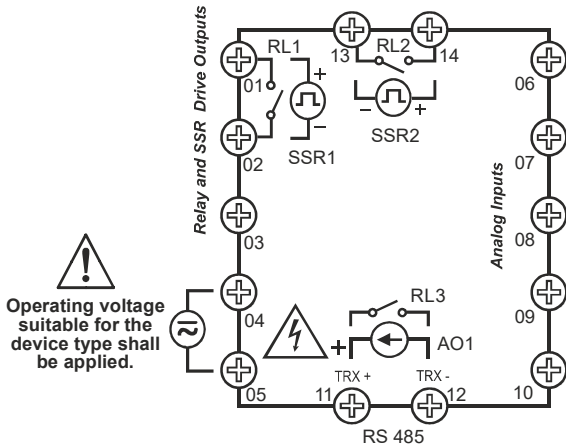

1st and 2nd control outputs can be selected as either Relay (RL1, RL2) or SSR (SSR1, SSR2).

Only one of the relay 3 output, Analogue output and RS485 Modbus options can be coded.

Analog output (AO1) mA or 0-10 V DC can be selected.

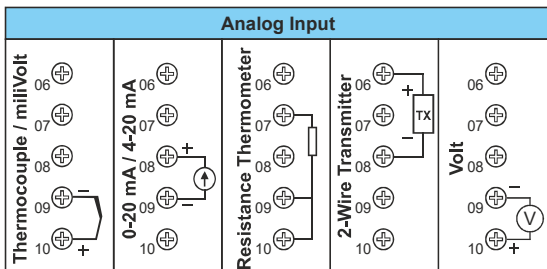

4. WARNINGS

E-48 controller is designed for panel mounting and should be used in an industrial environment.

- The package of E-48 controller contains; Controller, 2 pieces of mounting clamps, User manual and Guarantee certificate.
- After opening the package, please check the contents with the above list. If the delivered product is wrong type, any item is missing or there are visible defects, contact the vendor from which you purchased the product.
- Before installing and operating the controller, please read the user manual thoroughly.
- The installation and configuration of the controller must only be performed by a person qualified in instrumentation.
- Keep the unit away from flammable gases, that could cause explosion.
- Do not use alcohol or other solvents to clean the controller. Use a clean cloth soaked in water tightly squeezed to gently wipe the outer surface of the controller.
- It is not used in medical applications.



EU DIRECTIVE COMPLIANCE

Low Voltage Directive: EN 61010-1
EMC Directive: EN 61326-1



TS EN ISO 9001
Quality Management System Certificate

5. TYPE CODING

E-48 Series Universal Advanced Controller

E-48 - W - X - Y - Z

Relay Outputs

- None
- 1 relay (RL1)
- 2 relays (RL1, RL2)
- 3 relays (RL1, RL2, RL3)
- 1 SSR (SSR1)
- 1 SSR (SSR1) + 1 relay (RL2)
- 1 SSR (SSR1) + 2 relay (RL2, RL3)
- 2 SSR (SSR1, SSR2)
- 2 SSR (SSR1, SSR2) + 1 relay (RL3)

Analog Outputs *

- None
- 0-20 / 4-20 mA (AO1)
- 0-10 V DC (AO1)

Communication

- None
- RS-485 **

Operating Voltage

- 85-265 V AC / 85-375 V DC
- 20-60 V AC / 20-60 V DC

* Only one of the relay 3 output, Analogue output and RS485 Modbus options can be coded. For example, only one of the (X) and (Y) options can be coded as 1. Similarly, when the (W) option includes Relay 3 (W=3, 6 or 8) X and Y 1 cannot be selected.

** When E-48 Series controllers are ordered with communication, the E-IB-11 USB-RS485 converter can be used for PC connection. There are various control and monitoring software provided by Elimko.

6. TECHNICAL SPECIFICATIONS

Parameter	Description
Control Type	On/Off, PID, Heat/Cool, Floating and Feedback Control of Valves
Operating Voltage	20..60 V AC / 20..60 V DC or 85..265 V AC / 85..375 V DC
Relays / SSR	2 pieces SPST - NO 250 V AC 5A relays or 24 V DC 25 mA (SSR) drives
Dimensions (mm)	48 (Length) x 48 (Height) x 100 (Width)
Panel Cut-Out (mm)	45 (Length) x 45 (Height)
Analog Output	1 x 0..20 / 4..20 mA or 0..10 V DC optional
Analog Input	Universal (Note 1),
Communication (RS-485)	Available (RS-485)
Digital Input	None
Valve Feedback	None
Transmitter Supply	Available
Weight	115 g
Power Consumption	Max. 7 W (10 VA)
Operating Temperature	- 10 °C ... 55 °C
Storage Temperature	- 25 °C ... 65 °C
Memory	Maks. 100.000 write
Protection Class	IP-65 Front Panel, IP-20 Rear Case

Notes:

(1) Universal Input :

- Thermocouple : B, E, J, K, L, N, R, S, T, U
- Resistance Thermometer : Pt-100
- Current : 0-20 mA, 4-20 mA (Linear)
- Voltage : 0-50 mV, 0-1 V, 0.2- 1 V (Linear), 0-10 V DC, must be specified in the order.
- Resolution : 16 bit
- Accuracy : Thermocouple, Max. ±1.0 °C (Conversion and CJC error)
Resistance Thermometer, Max. ±0.5 °C (Conversion and wire resistance compensation)
Linear Input, Max. % 0.1

7. PARAMETER TABLE

Description		Min	Maks	Unit
INPUT SETTINGS Güç	inP 1 Analog Input 1 Type	Table 1		
	dP Decimal Point	0	3	
	SLo Analog Input 1 Linear Scale Lower Value	-199.9	999.9	EU
	SUH Analog Input 1 Linear Scale Upper Value	-199.9	999.9	EU
	UnIt Temperature Unit	°C	°F	
	oFSt Analog Input 1 Offset Value	-100.0	100.0	EU
	FLt Analog Input 1 Filter	1	15	s
	Snbr Analog Input 1 Sensor Broken Behaviour	Lo	Hi	
	RdS Modbus Address	1	127	
	bRld Modbus Baud Rate [48, 96, 192, 384 kbaud]	48	384	
Prty Modbus Parity [nonE, odd, EvEn]				

Description		Min	Maks	Unit
CONTROL SET SETTINGS SETP	SPSr Control Set Point Source	Table 2		
	SPLL Control Set Point Lower Limit	-199.9	SPHL	EU
	SPHL Control Set Point Upper Limit	SPLL	999.9	EU
	SPrr Control Set Point Ramping Rate	oFF	60.0	EU/min
	S-1 1. Step Set Value	SPLL	SPHL	EU
	t-1 1. Step Time	oFF	999.9	min
	S-2 2. Step Set Value	SPLL	SPHL	EU
	t-2 2. Step Time	oFF	999.9	min
	S-3 3. Step Set Value	SPLL	SPHL	EU
	t-3 3. Step Time	oFF	999.9	min

Description		Min	Maks	Unit
ALARM SETTINGS Rcnf	R1tP Alarm 1 Type	Table 3		
	R1SP Alarm 1 Set Point	-199.9	999.9	EU
	R1HY Alarm 1 Hysteresis	0.0	999.9	EU
	R1Lt Alarm 1 Lock	d5b	Enb	
	R2tP Alarm 2 Type	Table 3		
	R2SP Alarm 2 Set Point	-199.9	999.9	EU
	R2HY Alarm 2 Hysteresis	0.0	999.9	EU
	R2Lt Alarm 2 Lock	d5b	Enb	
	R3tP Alarm 3 Type	Table 3		
	R3SP Alarm 3 Set Point	-199.9	999.9	EU
	R3HY Alarm 3 Hysteresis	0.0	999.9	EU
	R3Lt Alarm 3 Lock	d5b	Enb	

Description		Min	Maks	Unit
OUTPUTS oCnf	CTYP Control Type	Table 4		
	CFrn Control Form [dIr, rEu]	dIr	rEu	
	CPrd Control Period	1	250	s
	nnPr Manual Mode Selection	d5b	Enb	
	trtn Floating Control Valve Travel Time	10	2500	s
	dbnd Dead Band	0.1	25.0	%
	oLL Control Output Lower Limit	0.0	oHL	%
	oHL Control Output Upper Limit	oLL	100.0	%
	oNr Control Output Manual Reset	oLL	oHL	%
	PonC PID Power On Behaviour	0	4	
	trLL Retransmission Scale Lower Value	-199.9	trHL	EU
	trHL Retransmission Scale Upper Value	trLL	999.9	EU
	rL1d Relay 1 Function	Table 5		
	rL2d Relay 2 Function	Table 5		
	rL3d Relay 3 Function	Table 5		
Ro1d Analog Output 1 Function	Table 6			
Ro1r Analog Output 1 Type	Table 7.1 ve Table 7.2			

Description		Min	Maks	Unit
PID SETTINGS Lüne	Rt PID Auto Tune	oFF	on	
	P1d PID Parameter Type	Std	Rdu	
	Pb+ Proportional Band +	0.1	999.9	EU
	Pb- Proportional Band -	0.1	999.9	EU
	It+ Integral Time +	oFF	9999	s
	It- Integral Time -	oFF	9999	s
	dIt+ Derivative Time +	oFF	2500	s
	dIt- Derivative Time -	oFF	2500	s
	HY5 Hysteresis	0.0	999.9	EU

Description		Min	Maks	Unit
SECURITY PrL	SCod Security Code	0	9999	
	dPrL Parameter Access Level	0	9	
	RPRL Parameter Setting Level	0	9	
	FCSt Factory Settings [oFF, LoRd, SRuE, dFLt]			

8. ACCESSING PARAMETERS

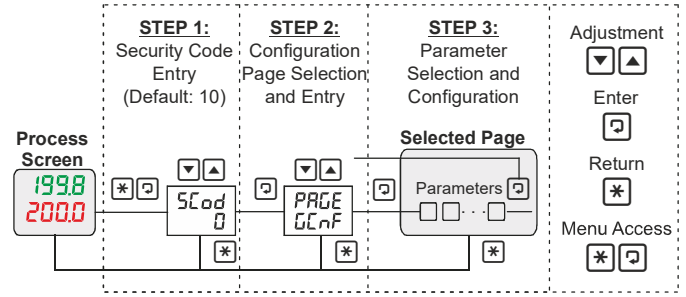

9. APPLICATION EXAMPLES

1) Input: Pt-100 Relay / Alarm1: 50 °C Low, Relay2 / Alarm2: 55 °C High
AO1: 4-20 mA PID Control Output

inP 1	R1tP	R1SP	R2tP	R2SP	CTYP	rL1d	rL2d	Ro1d	Ro1r
Pt	Lo	50.0	Hi	55.0	SCo	RL-1	RL-2	Co-1	4-20

2) Input: TC Type J, Relay1: On-Off Control Output, Relay2 / Alarm2: 350 °C High

inP 1	R2tP	R2SP	CTYP	rL1d	rL2d
J	Hi	350.0	SCo	do-1	RL-2

3) Input: TC Type K, Profile Control (Ramp up to 400°C in 10 minutes and wait for 60 minutes),
Relay1: PID Control Output, AO1: Retransmission Output (4-20 mA, 0-1200 °C)

inP 1	SPSr	S-1	t-1	S-2	t-2	CTYP	trLL	trHL	rL1d	rL2d	Ro1d	Ro1r
K	PrFL	400	10.0	400	60.0	SCo	0	1200	Co-1	RL-2	PuTr	4-20

Table 1. Input Type Options

b	Type B Thermocouple
E	Type E Thermocouple
J	Type J Thermocouple
K	Type K Thermocouple
L	Type L Thermocouple
n	Type N Thermocouple
r	Type R Thermocouple
S	Type S Thermocouple
t	Type T Thermocouple
U	Type U Thermocouple
Pt	Pt-100
0-20	0-20 mA
4-20	4-20 mA
0-50	0-50 mV
00-1	0-1 V
02-1	0.2-1 V
0-10	0-10 V (*)
2-10	2-10 V (*)

(*) Custom specified volt input

Table 2. Control Set Options

InC	Internal adjustment with keys
PrFL	With Profile Control

Table 3. Alarm Options

oFF	Off
Lo	Low Alarm
Hi	High Alarm
LoD	Low Deviation
HiD	High Deviation
LoB	Band Alarm (In)
HiB	Band Alarm (Out)

Table 4. Control Type Options

oFF	No Control
E	Single (Heat)
dCo	Double (Heat/Cool)
bnd	Floating Control of Valve

Table 5. Relay Output Options

Co-1	PID + (Heating)
Co-2	PID - (Cooling)
do-1	On-Off + (Heating)
do-2	On-Off - (Cooling)
RL-1	Alarm 1
RL-2	Alarm 2
RL-3	Alarm 3
RL-4	Alarm 4

Table 6. Analog Output Options

Co-1	PID + (Heating)
Co-2	PID - (Cooling)
PuTr	Process Value
SPTr	Control Set Value

Table 7.1. Analog Output Range

0-20	0-20 mA
20-0	20-0 mA
4-20	4-20 mA
20-4	20-4 mA

Table 7.2. Analog Output Range

0-10	0-10 V
10-0	10-0 V
2-10	2-10 V
10-2	10-2 V

For detailed information, you can access the comprehensive user manual of the device under the heading "User Manuals" at www.elimko.com.tr. You can also use the QR Code on the front for this.